

How To Use and Care For Your

**WHITE**

Zigzag Sewing Machine  
MODEL

565



## **LET'S SEW Perforating Plain Paper**

Your new wonderful machine was delivered ready for ZIGZAG stitching. Certain kinds of STRAIGHT stitching can also be done with the same NEEDLE PLATE and PRESSER FOOT which were on the machine when you received it. A NEEDLE was also properly installed, along with a partially filled BOBBIN underneath.

Without threading needle "sew" on a piece of PLAIN PAPER for a few minutes while you become well acquainted with the few easy-to-use CONTROLS pictured and briefly explained on pages 2 and 3; also 4 and 5. Later on you are urged to study all the operating details indexed on page 1 which you should skip for the time being.

Time saving wonder working sewing aids such as rufflers, binders, zipper sewing foot and many others are available at modest prices and sold by the dealer from whom you purchased your new machine.

## Contents of This Book Indexed

Study all these instructions carefully to obtain the wonderful performance your machine was designed and built to give. Constant reference to these instructions will reward you with troublefree sewing satisfaction.

<u>Subject</u>	<u>Page</u>	<u>Subject</u>	<u>Page</u>
Attachmentse--wing aids	12, 14, 15, 16, 17	Oiling Machine-- important	20
Fancy stitches (with cams)	2	Other care and maintenance	21
Bobbin--removal, threading, replace	9	Good sewing habits	4, 9
Button--sewing on with machine	12	Parts and functions controls	13
Buttonhole making by machine	11	Prssure-bar and Feet	3, 4, 15
Darning on machine	4, 12	Reverse stitching--sewing backward	4
Embroidery--stock designs and creative	2, 5	Stitch adjustments--ZZ and straight stitch-- stitch length per inch-ZZ width	3
Guarantee--parts warranty service	25	Take-up Lever	4
Light Bulb replacement	20	Tensions--upper and lower threads	10
Monogramming on machine	4, 12	Threading machine--needle--bobbin case	7, 9
Needle--proper one for the job	6	Troubles and remedies	22, 23, 24, 25
...installing in machine	7	Two simple precautions--start and finish make these a habit	4, 9
...threading	7		
Needle Plates--proper for job; changing	3, 15		

**To Sew Fancy Stitch Patterns Use the Cams** →

Look over your large assortment of molded plastic cams. Their color or colors do not affect function. A basic design such as diamond, half-moon, triangle, (as examples), is embossed on top flat side of each. The cam used guides needle to repeatedly reproduce its pattern.

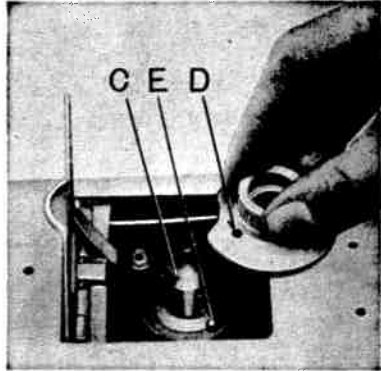
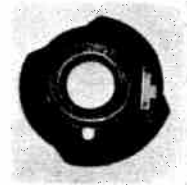

← **To Place A Replaceable Cam In Machine**

Do two things before selecting a cam. (1) Look directly below needle. Be sure presser foot and needle plate are those pictured at TOP LEFT next page. (2) turn controls BOTTOM RIGHT-next page until hanging lever can be moved from 0 to 5 on dial. Now lift open small cam chamber cover on top of machine. While holding ZZ Width Lever (next page) at extreme left (5), drop selected cam on spindle C. While still holding ZZ Width Lever, revolve cam, pressing down lightly, until hole in its bottom surface slides over pin E. Close cam chamber lid. Run machine slowly while you adjust Stitch Length Dial at MIDDLE LEFT next page. Most cam patterns appear best on Stitch Length Dial setting between 1/2 and 1-1/2.

**Changing Path of Needle Multiplies Variety of Designs** →

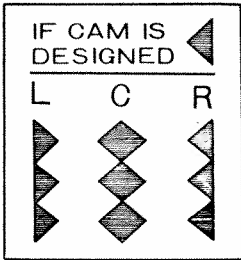

Lever NP can be set at Left, Center or Right. Each different position alters basic stitching line and therefore the appearance of most all zigzag stitch designs. Set lever NP at LEFT for straight stitching. Pull lever NP toward you and it clicks when sliding into the three position notches. Pushed in, lever NP avoids the notches, moving freely for hand controlled creative embroidery explained page 5; without a cam in machine.



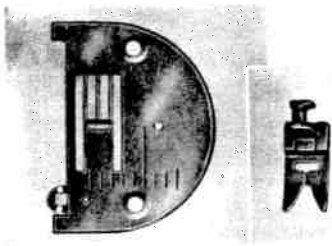

**BE SURE - For Zigzag Stitching**

← **Use This Needle Plate and Presser Foot**

These two parts are slotted crosswise to allow for needle swinging sideways while moving up and down. Slots are about 1/4 inch wide.

**For Straight Stitching Some Fabrics** →

Presser foot and needle plate with small

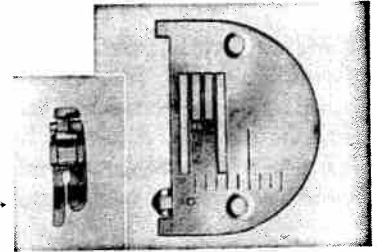

round hole instead of wide slot-best for finest STRAIGHT stitching in sheer, fine or very soft materials. For changing this standard equipment see page 15.



← **Setting Stitch Length - For Zigzag or Straight Sewing**

Turn this speedometer type dial CLOCKWISE to shorten, stich COUNTER-CLOCKWISE to lengthen for more stitches per inch. Refer to chart just below and find your favorite settings. Note the numbers for quick and easy duplication any time. Remember that material must move along or "feed" under presser foot in down position. Whenever it does not, stitch must be lengthened slightly.

**Dial Settings For Approximate Number of Stitches Per Inch**

Figures on indicator	0	1	2	3	4	5	6	7	8	9
Number of stitches per inch	No Feeding	60	40	20	16	12	10	8	7	6

**Setting Width of Hand Controlled Zigzag Stitching** →

**For Straight Stitching and Cam Controlled Zigzag Keep Lever at 0**

Adjust by turning horizontal finger rollers to numbers on dial or in between. To make the sides of buttonholes for example you may set left side number at 4; right side at 2.

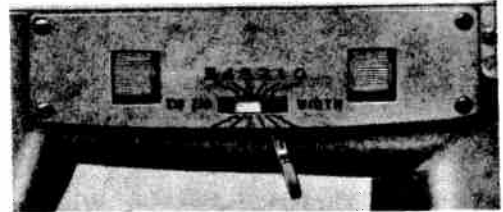

### To Sew Backward -- Zigzag or Straight Stitching →

Reverse stitch push button marked R is in base of machine directly below Stitch Length Dial. To sew backward, push button down and feeding teeth will move material in reverse to normal sewing direction as long as push button is held down. It's foolproof. When comfortably placed R button is released material sews forward again.

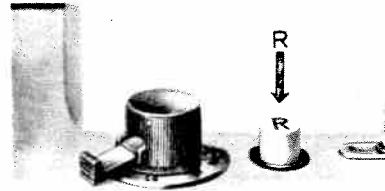

### ← To Drop Feeding Teeth for Darning or Monogramming

Control knob is just to left of Reverse feed button. To drop feed teeth entirely below needle plate surface, turn knob clockwise to extreme left position marked DN. For most normal sewing jobs knob will be in extreme right position marked HI. Occasionally the middle position (LO) will be ideal for very delicate filmy fabric-providing enough grip to feed material without tearing or scraping.

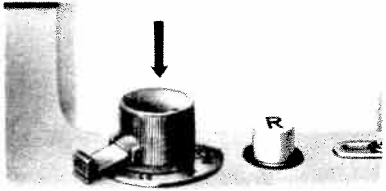

### ← Adjusting Pressure on Feed Teeth

For normal sewing, Bar (B) should be pushed down-its top about even with locking ring (A). Single finger pressure on edge of ring will release bar causing it to pop all the way up. That is position for most darning and monogram work with Feed Teeth in DN position. When sewing on delicate materials with Feed Teeth in LO position, the presser bar should be pressed down about half way.

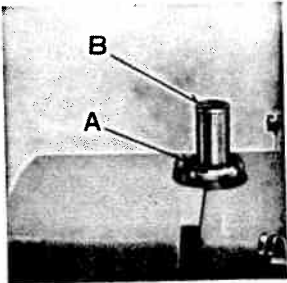

### A Good Sewing Habit -- The Take-Up Lever --

As each sewing operation is finished -- before starting machine -- while threading it -- ALWAYS when machine is not running be sure Take-Up lever is at top end of slot. Every time you stop machine turn the wheel by hand to position lever at highest point. The only exception is to oil.

**Never Run Threaded Machine Without Sewing In Fabric -- Be Kind -- Use Oil**

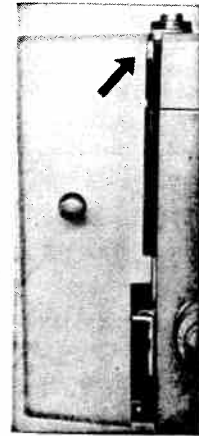

## You Move Some Levers For Plain Zigzag--Satin Stitches--Creative Embroidery

There is no limit to the variety of stitch patterns you can sew WITHOUT ANY CAM in machine. Get well acquainted with the use and effect of the four controls pictured below. Practice moving zigzag Width Lever from side to side while running machine. Do likewise with Needle Position Selector after pushing it in toward machine.

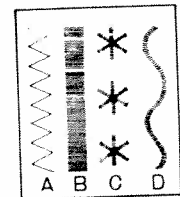

ZIGZAG STITCH WIDTH

LENGTH OF STITCH

NEEDLE POSITION SELECTOR

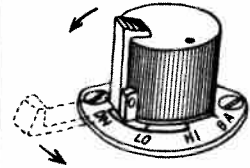
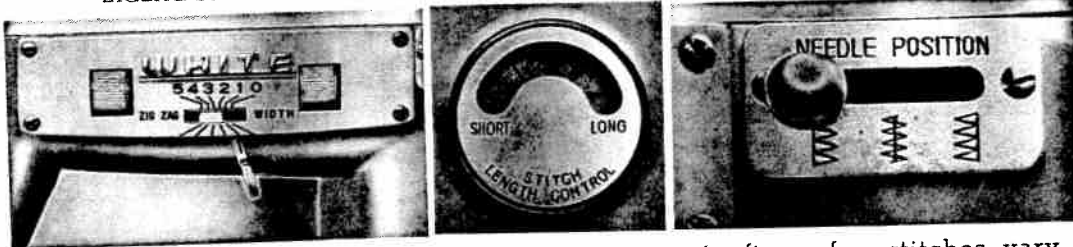

- Plain Zigzaging (A)** Set Stitch LENGTH Dial at 4--after a few stitches vary length as desired. Set Zigzag WIDTH so dial white area extends from 1 to 5. Now sew, holding Zigzag Width lever to the LEFT side.
- For Satin Stitching (B)** Set Stitch LENGTH Dial about halfway between 0 and 1. Set Zigzag Dial white area for width of stitch desired. Now sew, holding zigzag lever to LEFT For variations move Lever right, left, right while sewing.
- Make Flower Petals (C)** Turn drop feed knob to DN. Set ZZ Width Dial white area to extend from 1 to 4. Sew three or four stitches holding Zigzag lever to LEFT. Stop machine with needle down in cloth at center of petal design. Pivoting on needle, turn fabric to next petal and repeat steps to complete. Turn right side roller on of ZZ Width Dial so Lever goes right to 0. Put three or four stitches in center of design to lock threads.
- Serpentine Stitching (D)** Set ZZ Width Dial white area to extend from 2 to 5. Press Needle Path Selector Lever in toward machine--then as you run machine move that lever alternately from left to right continuing the motion back and forth in rhythm.

## Match Needle Size and Thread To Your Fabric - - Sew Like "A Professional"

### Approximate Stitches Per Inch Also Important

Fabric	Needle No.	Machine Stitches Per Inch	Cotton Thread	Mercerized Thread	Silk or Nylon
Extremely heavy tarpaulin, sacking, canvas, duck, etc	4	6 to 8	10 to 30	Heavy Duty	
Heavy upholstery fabric, tickng, denim, leatherette	3	8 to 10	30 to 40	Heavy Duty	
Medim heavy drapery fabric, velveteen, suiting, felt, terry, etc.	2	10 to 12	40 to 60	Heavy Duty	
Medium broadcloth, percale, gingham, linen, chintz, taffeta, sheer wool, shantung, etc.	1	12 to 14	60 to 80	50	A
Sheer voile, lawn, dimity, crepe, handkerchief linen, plastic film, etc	0	14 to 16 (Plastic film) 8 to 10	80 to 100	50	A
Very sheer chiffon, batiste, lace, organdy, ninon, net, marquissette, etc.	00	16 to 20	100 to 150	50	A

## Selection of Needle

A high proportion of home sewing is done with No. 14 size needle.  
For best results on all fabrics from sheer chiffon to canvas, see page 6 chart.

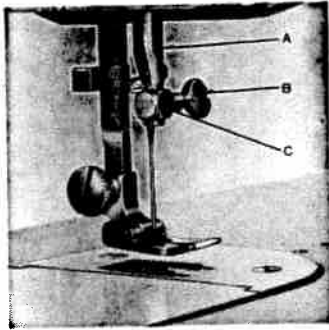

### ← Putting Needle In Machine

Turn machine wheel until needle bar (A) is at top position. Loosen needle clamp (B) with screw driver. When old needle drops out new one can be inserted. Find the one flat side on needle SHANK and hold that FLAT SIDE TO RIGHT as you push needle upward into clamp (C) as far as possible. While holding needle up there tighten screw (B) with screw driver.

### Threading Machine (Top Thread) and Needle→

Place thread spool on spool pin closest to needle. Lead thread through thread guides (A)--then down BETWEEN tension discs (B) from RIGHT to LEFT--and around to RIGHT again until thread enters check spring arm notch (C). Then pull thread leftward and down slightly UNDER large bar (D)--then immediately upward, and thread will enter rectangular opening in bar (D). Continue pulling thread upward and into take-up lever eye (E) from RIGHT to LEFT. Now down into bar (D) rectangle opening again--continuing down into needle bar thread guide (F) and then into needle eye from LEFT to RIGHT-- pulling three to four inches of thread through eye of needle.

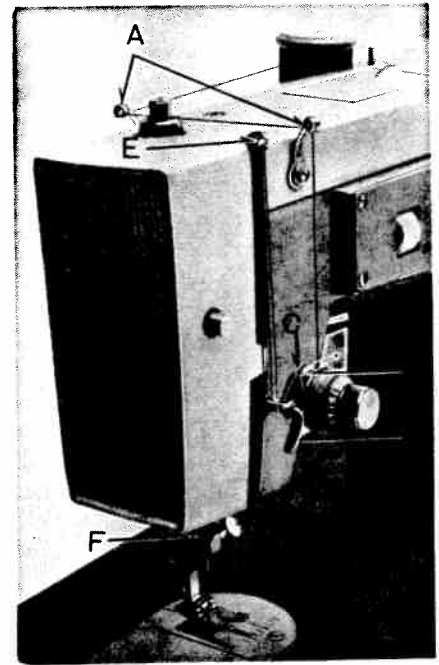

### Removing Bobbin Case From Machine →

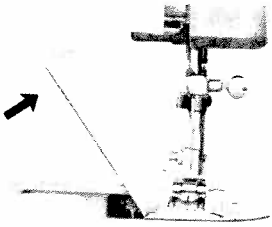

Lift hinged plate at left end of machine bedplate. Look down and slightly right: You will see the assembly pictured (right). With fingernail of left hand first finger under rear edge of latch (D), pull straight out and use raised latch as finger grip to remove bobbin case containing bobbin.

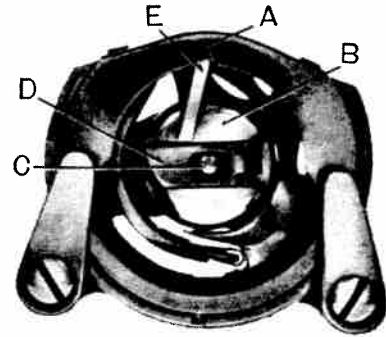

### ← To Replace Bobbin Case in Machine

Reverse above procedure. When sliding case onto shuttle center stud (C) be sure that threaded finger (E) is directly upright so it will enter shuttle race notch (A) as you push case (B) into sewing position, finally releasing latch (D) to hold it.

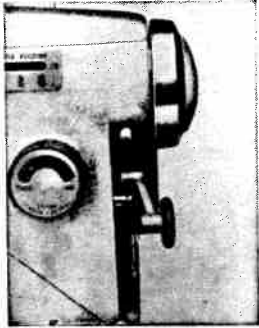

### ← Winding (Refilling) A Bobbin

Place a spool of thread on one of the spool pins, lead thread through the upper thread guides on the arm, and down through the tension disc (T) at the base of the machine. Run end of thread through a hole in the bobbin edge and place bobbin on spindle (S) of bobbin winder, fitting the notch on bobbin over small pin on spindle. Push bobbin winder pulley (P) against hand wheel which will declutch the sewing

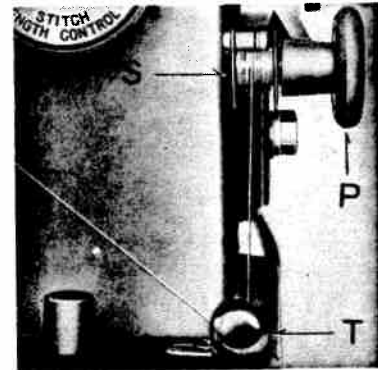

mechanism. Hold thread end loosely and start machine slowly. Bobbin will stop winding when it is filled. By moving the bobbin winder from the hand wheel it will engage the sewing mechanism. Approximate one turn of the hand wheel may be required to completely engage sewing mechanism.

## Installing Filled Bobbin and Threading The Bobbin Case

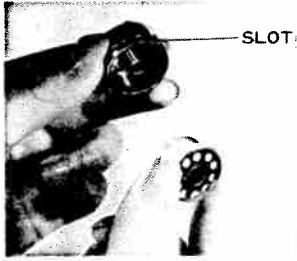

Hold bobbin case with slot in its edge up (left). Hold bobbin with fingers of other hand so that end of thread points in **CLOCKWISE** direction. Insert bobbin in case and pull thread into case edge slot (**RIGHT**). Then continue pulling thread under tension spring and into fork-shaped opening of spring (**RIGHT**), until about three inches of thread protrudes.

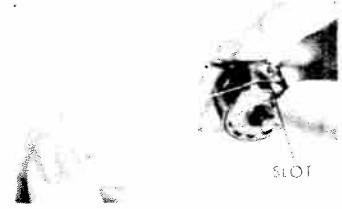

## Put Bobbin Case Back In Machine By Reversing Procedure Page 8

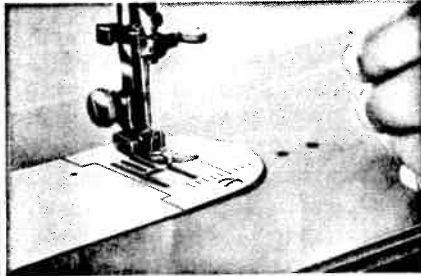

### ← The Last Step Before Sewing

Hold end of thread through needle loosely in left hand and turn machine wheel **COUNTER-CLOCKWISE** until needle goes down and comes back up. The needle thread you hold will be looped by bobbin thread from below. Pull loop out straight and place **BOTH** threads under presser foot slot. Continue pulling them toward back of machine for three to four inches.

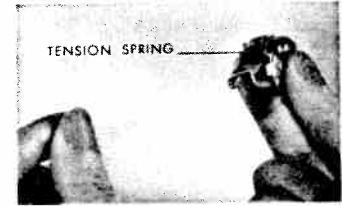

### Finish Every Sewing Step The Right Way →

At end of each sewing operation turn machine wheel **COUNTER-CLOCKWISE** by hand until Take-Up Lever and Needle are at highest position. Raise Presser Foot and draw fabric toward back and slightly left, keeping threads **UNDER** presser foot. Clip threads with sharp scissors or by raising them over top of Machine Thread Cutter just above the presser foot. Then pull down to cut threads using both hands to avoid bending needle. Leave ends of both cut threads under presser foot.

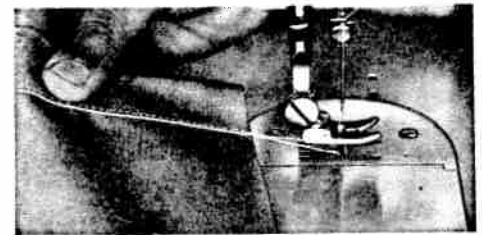

## Adjusting the Tensions for Properly Balanced Stitching

The shaded portions of drawings below represent the fabric enlarged many, many times to illustrate the lock-stitch principle--how and where both threads should entwine **WITHIN** fabric thickness.

Hold finished side of material upward when inspecting stitching.

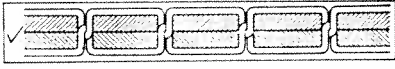

NEITHER THREAD PERFECTLY FLAT  
STITCHES PROPERLY LOCKED WITHIN

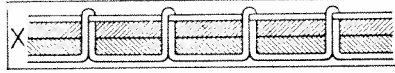

TOP THREAD FLAT OR LOOSE  
TOP TENSION TOO TIGHT

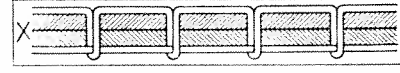

BOTTOM THREAD FLAT OR LOOSE  
TOP TENSION TOO LOOSE

### ← To Tighten or Loosen Top Tension

First be sure that Presser Foot is **DOWN**--resting on fabric. (When raised, top thread tension is released). To **TIGHTEN** needle thread tension turn numbered dial (left) **CLOCKWISE**. To relieve tension turn dial counter-clockwise. The higher the number at which dial is set, the heavier the tension on needle thread. Before attempting any tension adjustments be doubly sure that machine is completely and properly threaded and that Presser Foot is **DOWN**. If tension adjustment of needle thread does not produce properly balanced stitching--only then do you consider adjusting tension on bobbin case (lower) thread.

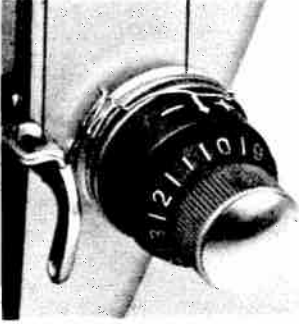

### To Loosen or Tighten Bobbin Thread Tension →

This adjustment is rarely necessary unless you have a sewing project calling for very unusual thread in the bobbin--i.e. elastic. To adjust tension on bobbin thread merely turn the small screw in outer rim of Bobbin Case (right). Turn screw a little at a time as you pull thread to test tension on it. Turn screw **CLOCKWISE** to **INCREASE** tension--the other way to ease it.

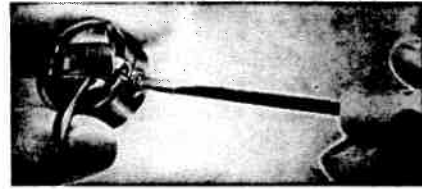

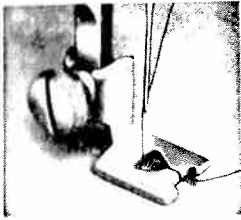

## Make Buttonholes With Your Machine

First be sure ZIGZAG Needle Plate is on machine. Next replace other Foot with the BUTTONHOLE Foot lock left. Then follow these directions in making a test buttonhole in scrap fabric.

Start by marking fabric with tailor chalk or basting stitches, both ends of buttonholes you want to make, exactly where you want them.

To make buttonholes in sheer or very soft fabrics place tulle or blank newsprint type paper under fabric. Tear away the paper after buttonhole is completed.

**STEP 1.** Set Needle position Selector at LEFT position. Set ZZ Width (white area at 5 on left side about 2 on right. Set Stitch LENGTH dial - not far around from its 0 marking. Turning machine wheel by hand, lower needle into fabric where you have marked the starting end of buttonhole. Now sew slowly to your mark at the other end and you will have made one side of buttonhole. Stop machine with needle down in fabric at right side of ZZ stitching completed.

**STEP 2.** Raise Presser Foot and using needle in fabric as a pivot turn the fabric completely around, end for end. Now turn Feed Teeth Knob to DN position. Then lower Presser Foot and raise needle. Next turn move ZZ Width Lever to left and hold it at 5 on dial while sewing four or five stitches.

**STEP 3.** Raise needle out of fabric and turn FEEDING Teeth Knob back to HI position. Now sew second side of buttonhole until it reaches mark on fabric at right side of ZZ stitching just finished.

**STEP 4.** Turn Feed Teeth Knob to DN position. With Presser foot still down RAISE needle out of fabric. Move ZZ Width to left and hold on 5 while you sew four or five stitches to complete bar-tacking. Leave Presser Foot down and raise needle out of fabric.

**STEP 5.** Spin right side ZZ Width roller to 0 on dial Then make two or three stitches to tie threads securely and prevent ravelling. Cut buttonhole open with a buttonhole cutter or seam ripper, being very careful to avoid cutting any stitching. Turn Feed Teeth Knob back to HI position ready for you next project..

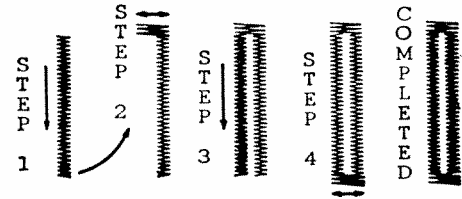

**Your Machine Will Sew On Buttons →**

Another operation which takes longer to explain than to do)

Put Button-Sew-On Foot on machine. Turn Feed Knob to DN. Set Needle position Lever in LEFT position. Set left of ZZ Width Control at 5. Place fabric and button so its LEFT hole is directly under needle and gently lower foot to hold button. Turn machine wheel slowly by hand until needle goes down and back up through left hole. Continue turning wheel until needle moves to right and starts down again. Now aim it at hole on RIGHT by turning right side Roller in ZZ Width Control Panel.

Continue turning wheel by hand to be sure needle clears button as it moves in and out both holes in button. Then slowly sew five or six stitches and stop machine with needle down in LEFT hole. Turn ZZ Width (right side roller) until Lever slides back to 0. Take a few stitches in left side hole only, to tie threads. To provide buttoning space for heavier materials place a rounded toothpick atop button between the two holes while sewing it on.

**Embroidery - Monogramming - Darning**

← **For Finest Results Use A Hoop**

Remove Presser Foot from machine. Turn Feed Knob to EMBR. Release Presser Bar pressure (page 4). Stretch fabric tautly in an embroidery hoop and angle hoop edge under needle. Set Stitch Length Dial as desired (usually at a low number). Lower Presser Bar Lever (otherwise there is no tension on thread), and begin sewing. Run machine at fairly high speed while moving hoop around rather slowly, using both hands to keep fabric flat on machine at all times. With care you can follow a stamped or traced design, or close a hole or tear effectively. Keep fingers away from the needle.



## Know Your Machine - - Its Functional Controls and Components

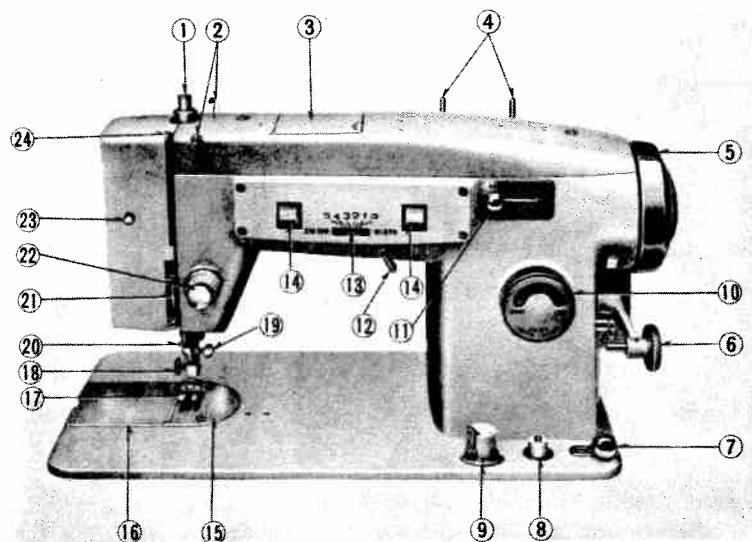

- |                         |                             |
|-------------------------|-----------------------------|
| 1 Presser Bar           | 10 Stitch Length Dial       |
| 2 Thread Guides         | 11 Needle Position Selector |
| 3 Cam Chamber           | 12 ZZ Stitch Width Lever    |
| 4 Spool pins            | 13 ZZ Stitch Width Panel    |
| 5 Wheel                 | 14 ZZ Width Control Rollers |
| 6 Bobbin Winder         | 15 Needle Plate             |
| 7 Bobbin Wind Tension   | 16 Hinged lift Plate        |
| 8 Reverse Sewing Button | 17 Presser Foot             |
| 9 Feed Teeth Knob       | 18 Foot Holding Screw       |

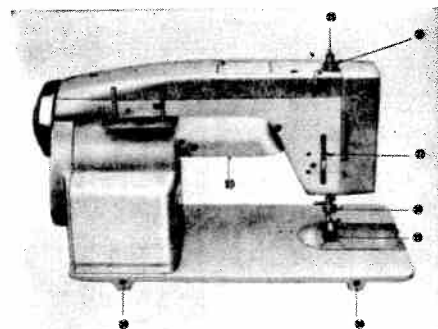

- |   |
|---|
| 19 Needle Clamp and Screw                 |
| 20 Thrad Guide to Needle                  |
| 21 Rectangular Thred Guide                |
| 22 Tension Regulator                      |
| 23 Light Switch                           |
| 24 Take-Up Lever                          |
| 25 Pressure Bar                           |
| 26 Bar Release Ring                       |
| 27 Presser Foot Lifter                    |
| 28 Thread Cutter                          |
| 29 Feed Teeth                             |
| 30 Cabinet or portable<br>Hinge Pin Holes |
| 31 Handle                                 |

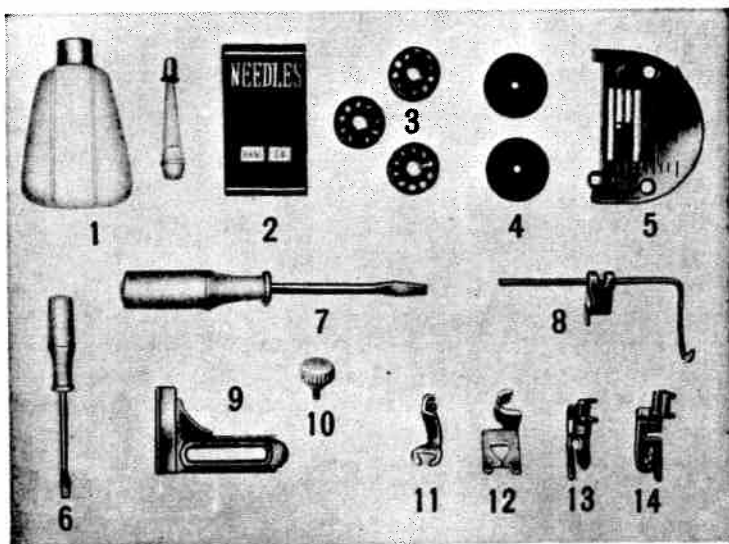

### Standard Equipment Accessories

- |  |   |
|--|---|
| 1 Plastic oiler                            | 8 Quilting Rows Spacer                      |
| 2 Needles (5)                              | 9 Stitching Guide-assures even seams        |
| 3 Bobbins (3)                              | 10 Thumb Screw for stiting guide            |
| 4 Felt washers (2) side over spool pins    | 11 Button Sew-on Foot                       |
| 5 Needle Plate for Straight Stitching only | 12 Buttonhole Foot                          |
| 6 Small Screw Driver                       | 13 Presser Foot for Straight Stitching only |
| 7 Large Screw Driver                       | 14 Narrow Hemming Foot                      |

**To Change Needle Plate →**

Be sure Presser Foot is UP and needle at top position. Raise hinged cover plate (attached to needle plate) and leave UP. Carefully remove screws holding needle plate-- and gripping the raised cover plate slide entire assembly off machine. Set Stitch WIDTH Lever at 0.

Turn assembly over--under side upward--holding needle plate in one hand, hinged cover plate in the other. Notice that two small pins--one at each side of cover plate--fit into grooves at each end of assembly. One pin is under spring-hinge at one end--the other pin is unobstructed. Lift that pin out of groove--then the other pin can be freed as the tongue on cover plate is separated from the spring latch on needle plate. Just reverse the entire procedure to attach another type of needle plate to the hinged cover plate and re-install the changed assembly on machine.

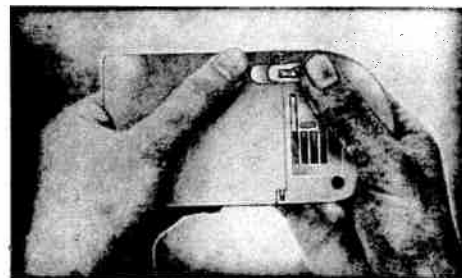

**CAUTION - - After Changing A Needle Plate or Presser Foot Always Turn Machine Wheel by Hand While Needle Goes Down and Comes Back Up. Such a Production Avoids Breaking Needle and Damaging Machine.**

**← To Change Presser Foot**

Be sure Presser Foot and needle are both UP. Loosen thumb screw A with fingers or screw driver until Presser Foot slips down and off. To replace with another foot merely reverse the procedure. After changing a foot always hand-turn machine carefully to be sure needle does not strike foot.

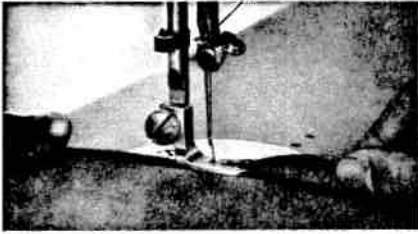

### ← Use The Narrow Hemmer To Sew Like A Professional

Practice first with scrap material. With fingers, crease a fine ( $\frac{1}{8}$ " wide) DOUBLE fold from starting edge for about two inches. Take a couple hand needle fine stitches to hold fold at starting edge, leaving at least two inches of threads dangling. Holding both ends of the hand creased fold, slide it underneath the Narrow Hemmer Foot. Slip the middle portion of FOLD into the SCROLL of Hemmer. (Moving it back and forth slightly you will observe how the scroll rolls the fine narrow hem into

position.) Keeping the scroll just barely FILLED with fabric, finally pull creased portion toward you until starting edge is under needle, then lower Narrow Hemmer onto fabric. As you slowly run machine (set at fairly short stitch length), gently pull on the hand needle thread ends through a few starting inches of your entire hem. Keep on guiding fabric with SLIGHT pressure to the RIGHT and it will continue making a double turn through the scroll.

### To Make A French Seam

With finished sides of fabric face to face place edge of top piece  $\frac{1}{8}$  inch inside the edge of bottom piece. Follow same steps as for plain narrow hem in a single piece of fabric.

### ← Stitching Guide--Quilting Rows Spacer →

For perfectly straight and even stitching about  $\frac{1}{2}$  inch OR MORE from any edge of fabric, use the Guide (left). Fasten it to machine bedplate, with its thumb screw in threaded hole about 2 inches to the right of needle. Attach Quilting Guide by placing its pronged holder between

upper portion of presser foot and its clamp thumb screw -- by first loosening and then re-tightening screw. Adjust curved bar of guide to barely rest on a row of stitches previously sewed. Then successive rows will be equally spaced.

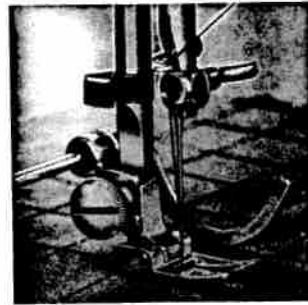
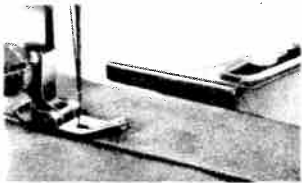

## BASTING STITCH

1. Use the zigzag foot and needle plate.
2. Set needle position selector at extremely left hand position (E)
3. Thread the needle as illustrated below.  
 Loop thread around the front of the needle by passing the thread to the right and to the left on the back side of the needle.  
 Then thread from left to right.
4. Pick up lower thread, see page 9.
5. Pull and down the lever of drop feed knob, and turn the knob unti-clockwise to BA position, then pull up the lever again.
6. Drop disc cam for basting stitch on spindle C Page 2
7. While still holding zz width lever, revolve cam, pressing down lightly, until hole marked in red slides over pin C
8. Adjust feed regulator to number 3 or 4. The high number is the longest stitch
9. Cotton thread is the best for basting and a tension adjustment may be required for light weight fabrics.
10. For best results sew at a slow speed approximately 600 to 700 stitches per minute

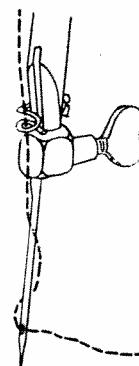
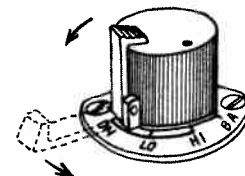

### Double Lift on presser foot

Double Lift will help you rack embroidery hoop under the presser foot. Presser foot will lift  $\frac{1}{4}$  inch high and if required, set needle in its highest position, then lift the presser foot up to  $\frac{7}{16}$  inch high.

### Circle Stitch

Circle Stitches designs are easily made by using a straight pin as a pivot. First hole in cover plate will produce a 2 inch diameter circle with the following holes 3 inch, 4 inch, 5 inch and 6 inch diameter circles can be made.

Select the diameter circle you want to sew and proceed as follows

- (1) Place pin in fabric
- (2) Put pin in selected hole and material under presser foot
- (3) Straight stitching, zigzag stitches-or any decorative stitch design can be sewn
- (4) When sewing keep finger with slight pressure on top of pin
- (5) When sewing with a decorative stitch pattern can try setting the drop feed knob at the basting stitch position for a different type of stitch design.
- (6) Decorative scallops can be made by sewing only a part of the circle and turning [the] material inside out.

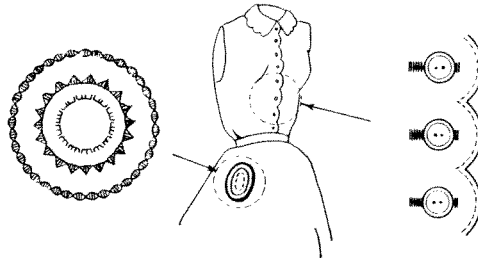

**Many More Time-Saving Wonder Working Attachments  
Available From Your Dealer At Modest Prices--Here Are Some  
Order them by genuine part numbers shown**

**Ruffler-Pleater No. 1403**

Just on one set of curtains for the house, you will save hours and hours of time and nerve-racking tediousness by using your machine and a Ruffler. For pleating skirts and slip covers; making gift aprons, children's clothes with ruffled finishing touches; adding fullness to dress bodices, are just a few of the many uses for this versatile attachment. Also while ruffling a trimming you can sew it on the main fabric simultaneously. Despite its wide range of practical applications it is amazingly simple to use.

**Zipper Sew-In and Cording Foot No. 1873**

Needed to sew in zippers by machine. Permits stitching very close to the metal fastener for smooth, secure results in a jiffy. Adjustable for stitching on either side of foot--left or right. Also needed for Cording.

**Darning Spring No. 4990**

Of great assistance when Darning or Monogramming with Presser Foot removed from machine--especially when using a hoop. It just slips over the needle and hooks onto needle clamp.

**Edgestitcher No. 76554**

The fast, foolproof and fine-finish way to sew pipings, edgings and lace insertions. Easy to use--with a range of slots to guide the fabrics and the operator.

**Binding Applier No. 74159**

Another tremendous time-saver. This attachment folds plain, flat bias binding from a roll; also hand-cut bias binding, and applies it to edge of material at the same time. Also does a fine job of applying standard sizes of folded and two-tone (two different colors) bindings simultaneously. Almost a must for making children's garments fast and easily.

**Hemmers for Four Popular Hem Widths**

To go with the Narrow Hemmer which came with your machine. Order by number according to the width of hems wanted:  $\frac{1}{4}$  inch-No. 76550;  $\frac{3}{8}$  inch-No. 76551;  $\frac{5}{8}$  inch-No. 76552;  $\frac{7}{8}$  inch-No. 76553.

**Attachment Holder No. 82528**

**NECESSARY FOR ATTACHMENTS ABOVE**  
To use the Edgestitcher, Binding Applier, or wider Hemmers on your machine you must first install the Attachment Holder in place of any Presser Foot.

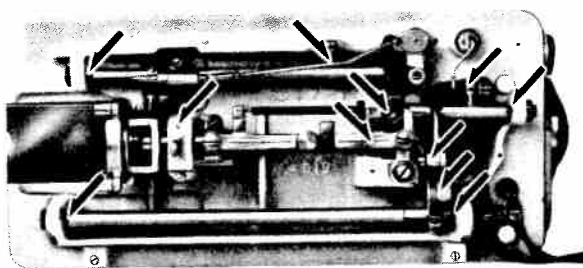
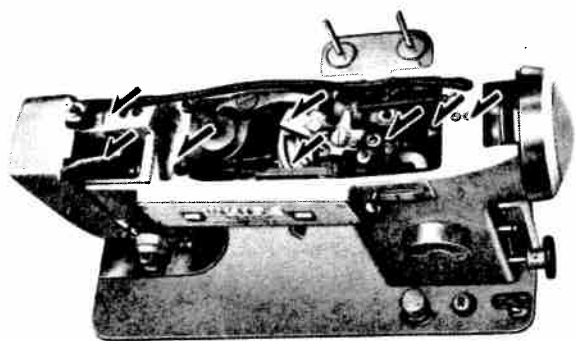

### To Oil Machine--Take-up Lever in LOWEST Position

Use only Sewing Machine Oil available from your dealer--avoid other grades. Never over-oil. ONE DROP at the points indicated by arrows above is sufficient. Oil machine when starting a sewing project--or during such. NEVER oil machine before putting it away for a few weeks or longer. When and how often to oil is a matter of good judgment because nobody but you knows how much and for how long your machine will be operating. Just remember your machine is a mechanical device with many moving parts.

### Oiling Point Inside Face Plate--Replacing Light Bulb →

These four points normally require oiling only every third or fourth time the average machine is oiled elsewhere. For access to them merely pull face-plate cover open as show--which also gives access to the bayonet--socket type light bulb, available from your dealer. It is a wise precaution always to keep an extra new bulb on hand in the accessory box.



### To Clean and Oil Shuttle--Lift and Tip Machine Backward

Occasionally the shuttle assembly gets clogged with lint, loose threads or fabric dressings. Running machine threaded without fabric under presser foot can also clog and tightly jam the shuttle. Cleaning this assembly is simple. Cabinet or portable hinges will hold machine at an angle. Underneath machine at its left end you will see the assembly pictured here.

With needle at its TOPMOST position--remove Bobbin Case (Page 8). Push top end of BOTH clamps (B) outward--permitting removal of shuttle race covering (C) and shuttle (D)--holding latter by its center pin. Thoroughly clean ring (C) and shuttle (D)--ALSO the shuttle race, the cavity IN THE MACHINE where shuttle functions. If any scraping is necessary be sure to cloth-cover the screw driver blade.

Before re-assembly put one drop of oil on a finger-tip and run it around the outer edge of shuttle (D). Holding shuttle (D) by its center pin and its half-moon body toward you, push in and wiggle it slightly until you feel it fitting firmly against shuttle driver, where it will stay put. Then replace race cover ring (C)--fitting pin in its LOWER edge into notch. Push both clamps (B) inward until they snap onto their holding pins. Last insert Bobbin Case (Page 8) and your machine should be ready for sewing.

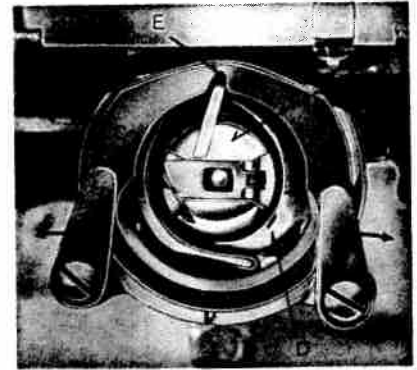

See page 23

### Lint Cleaner

Lint and dust may cause trouble on surface of shuttle hook or shuttle body. Lint Cleaner will make you free from this trouble.

Lint Cleaner to be set with shuttle driver and easily removed. Take off Lint Cleaner each time when you are cleaning shuttle race.

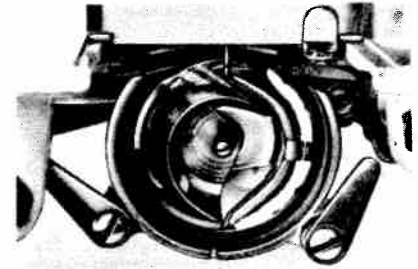

## Adjusting and Changing "V" Belt

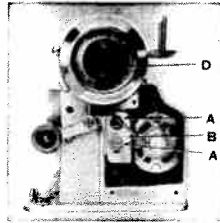
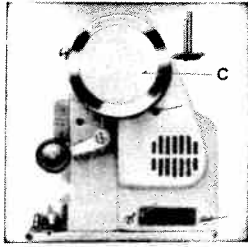

To do this, follow these instructions; 1. Remove screws holding rear cover. 2. Remove rear cover. 3. To adjust "V" belt loosen screws (A) and move bracket (B) up to loosen belt and down to tighten. 4. To move "V" belt;-

- A. Place bobbin winder in off position,
- B. Loosen screw (A) and move bracket (B) to its highest position.
- C. Remove plastic cover (C) with screw driver being careful not to break it.
- D. Remove spring stop (C).
- E. Move hand wheel away from machine to form a gap through which the belt will pass.
- F. Slip belt off motor pulley and then over hand wheel.
- G. Replace "V" belt by slipping it over hand wheel and then over motor pulley.
- H. Move hand wheel back to its original position and replace spring (D), plastic cover (C) and rear cover.

### **Fix-It-Yourself Hints To Avoid Costly Home Calls**

Long experience has established the absolute fact that their users rather than sewing machines necessitate approximately three-fourths of all service calls. To know the cause of any trouble usually makes correction of it relatively simple.

Damaged, defective, or the wrong needle for the job--incorrect threading--faulty tension adjustment--thread or lint in the shuttle and its race-way--cause more difficulties with a sewing machine than all other sources of trouble combined.

Re-check with this manual before going to the telephone to request service. A little time spent with this book, plus some patience might save you money time after time.

**IF YOUR MACHINE IS NOT SEWING PROPERLY LOOK THROUGH THE FOLLOWING PAGES.**

Trouble	Probable Cause	Correction
Skipping Stitches	Bent needle	Discard and replace
	Needle placed incorrectly in clamp	See instruction page 7
	Too fine a needle for thread being used	See needle and thread chart, page 6
Irregular Stitches	Upper thread tension too loose	Tighten upper tension
	Improper threading	See threading instruction, page 7
	Bobbin not wound evenly	Rewind bobbin
Uneven Stitches	Pulling or holding material	Avoid pulling or holding material, just guide it
	Not enough tension on upper thread	Increase tension
	Poor quality thread	Try different thread
	Needle too fine for thread being used	See needle and thread chart, page 6

Trouble	Probable Cause	Correction
Upper thread breaking	Improperly threaded	Refer to threading instructions page 7 and rethread machine.
	Too much tension	Loosen tension on upper thread by turning thread tension dial to lower number.
	Starting with take up in incorrect position	Always start sewing with take up lever in higher position.
	Improper setting of needle	Refer to needle setting instruction page 7
Material puckering	Bent needle or eye of needle too sharp	Try a new needle
	Bent or blunt needle	Discard all blunt or bent needles and replace with new
	Tensions too tight	See tension adjustment page 10
	Dull needle	Change needle
	Stitch length too long	Reduce stitch length-some fabrics cannot be sewn with a long stitch

Trouble	Probable Cause	Correction
If Machine Binds or Locks	Thread or lint in race. Likely machine was run without sewing fabric.	Understandably, many users think their machines have broken down the first time they experi- ence a clogged shuttle, or hook, as sometimes described. However, such jamming is easily corrected.
Machine not operating.	Bobbin winder near hand wheel.	Move bobbin winder to off position away from hand wheel.

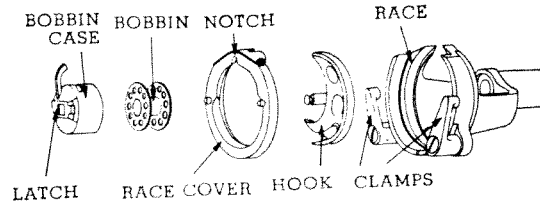

The bobbin case--shuttle race cover--shuttle (hook)--must all be removed from the shuttle race, which is built into the machine. Move needle and take-up lever to their highest points. Next, lift and tip machine backward. It will remain at an upright angle resting on its cabinet or base hinges--making the parts underneath bedplate readily accessible. Lift fingernail latch on bobbin case and remove from machine. Push top ends of both race clamps outward (in opposite directions). Now the shuttle race cover can be removed--usually dropping into your hands. Finger-grip the center pin of shuttle (hook) and remove from machine. Thoroughly clean shuttle race (in machine) race cover and shuttle

itself. If some scraping is necessary to get every bit of thread and lint removed from edges or corners, be sure to cover screw driver with soft cloth. Before reassembling all parts into machine put one drop of oil on a finger-tip; then run the finger tip around outer edge of shuttle (hook). Avoid excessive oil on shuttle rim. Any more than a film of oil may cause some to run into the bobbin case; soaking and discoloring the bobbin thread. When lowering machine into sewing position grasp it with both hands ABOVE the bedplate. Hence you will not be risking scraped or bruised fingers should the machine slip and drop too fast and hard.

Printed in U.S.A.